

Includes prices for 2022/2023

YOUR BATHROOM IN 3D

Explore the reasons why you should be exploiting the cost savings, time benefits and return value on your investment in 3D visualisations for your bathroom product marketing images.





START DOING THINGS DIFFERENTLY

Stop thinking that CGI will never be as good as photography or that 3D models will never get the detail of your products right. The images in this brochure should change your mind about that, and with a changed mind comes opportunity. An opportunity to reap the benefits of doing things differently. We take away the headaches of managing photographers, set designers, location scouts, and much more. We will slash your sales image production time, save you money and future proof your investment in everything 3D. So you end up with more time on your hands, a more efficiently spent budget and better looking brochures and website.

FULL ROOM SET IMAGES

Surround your products with the latest decor styles, colour themes and textures and be the mastermind of your perfect 3D photo shoot. Be as involved in the creative process as you want to be but with no location to find, no logistic headaches and no studio or on-site management, how will you spend all that extra free time you've suddenly got?

See how past clients have enhanced their brand and created exceptional imagery overleaf.

*BENEFITS.

Re-use room set for updates or new designs at a fraction of the cost.
Revisit months/years later with no restrictions.

Variants of your 3D room can be created for next to nothing.

Perfect locations can be created easily.
Experiment with decor styles.

£600

Prices start from:

** Over traditional photography*



Do you not covet fashionable, stylish and aspirational images like these for your products?

Style research, mood board production, whole room design, lighting, camera angles and propping all carried out by the same supplier. No fuss.



What could be simpler?

One supplier contact, online communication, account handled for fast and responsive reactions to fulfill all your requirements.

Beautiful images and designs are not just reserved for large companies with substantial budgets any more.



PRODUCTS UP CLOSE

Focusing on the details of your products can be just as enticing and eye catching as a full room display. Here is where you can really bring your products to life with simulations and stunningly realistic camera effects bringing your new brochures alive for your customers.

BENEFITS.

Get the perfect angle and the perfect

lighting to showcase your product

A cheaper alternative to a full room
setting

The focus is all on your product

£350

Prices start from:





**Irresistable, influential
3D renders of every
shape and feature of
your product.**

Harness the cutting-edge power of technology to create brochures and sales images that stand head and shoulders above your competitors.



Experiment with light, play
around with positioning,
explore different textures and
investigate camera angles - you
probe and scrutinise until it's
right for you.





IDEAL FOR SOCIAL CHANNELS

Respond quickly to social trends or home styling fads that gain traction by updating your images easily with new product designs or create a new buzz/campaign with images that reflect the current mode or style.

Try doing that with physical sets and photography!

£350

Prices start from:



£700

Prices start from:

MAKE YOUR PRODUCTS COME ALIVE IN 3D MOVIES

Take your brand appeal to the next level and captivate your audience, highlight hidden features and create an ongoing story for your social media and website channels by re-using the 3D assets you invested in.

Exploit the many benefits and efficiencies of 3D visualisation for your bathroom brand TODAY.

REVEAL HIDDEN FEATURES

By re-using the 3D assets you have already created you can generate amazing and illustrative technical and explanatory images that reinforce and enhance your selling message. No longer limited to line drawings and awkward installation photo's your brochures and online presence can be enhanced with colourful, realistic technical illustrations.



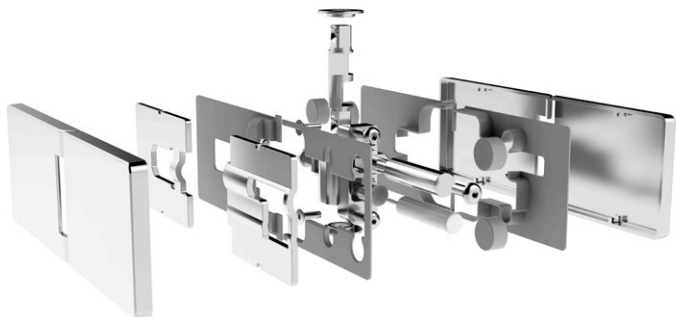

What makes your products special? Why are you different to your competition? 3D CGI gives you and your teams the tools to fully explain all of your selling messages.

Any type of setting can be imagined and realised. No physical location required.





**DO YOU LIKE
WHAT YOU SEE?**

**Then give us a call and have a chat with
one of the team about how you would like
to use 3D in your next project**

We can save you time, money and stress.

22 years of creating wonderful 3D images has left us with a
reputation of knowing what we are doing.



Red and Gray Limited
3D Creative Studio

**COMPANY DATA
AND CONTACT**

COMPANY NAME :

RED AND GRAY LIMITED

COMPANY ADDRESS

CENTRIX HOUSE
KEYS BUSINESS VILLAGE
CANNOCK WS12 2HA

CONTACTS :

M : ENQUIRIES@REDANDGRAY.CO.UK

W : WWW.REDANDGRAY.CO.UK